

Please write clearly in block capitals.

Centre number

Candidate number

Surname _____

Forename(s) _____

Candidate signature _____

I declare this is my own work.

A-level PHYSICS

Paper 1

Wednesday 24 May 2023

Afternoon

Time allowed: 2 hours

Materials

For this paper you must have:

- a pencil and a ruler
- a scientific calculator
- a Data and Formulae Booklet
- a protractor.

Instructions

- Use black ink or black ball-point pen.
- Fill in the boxes at the top of this page.
- Answer **all** questions.
- You must answer the questions in the spaces provided. Do not write outside the box around each page or on blank pages.
- If you need extra space for your answer(s), use the lined pages at the end of this book. Write the question number against your answer(s).
- Do all rough work in this book. Cross through any work you do not want to be marked.
- Show all your working.

Information

- The marks for questions are shown in brackets.
- The maximum mark for this paper is 85.
- You are expected to use a scientific calculator where appropriate.
- A Data and Formulae Booklet is provided as a loose insert.

For Examiner's Use	
Question	Mark
1	
2	
3	
4	
5	
6	
7–31	
TOTAL	

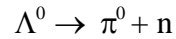

Section AAnswer **all** questions in this section.**0 1**The neutral lambda particle Λ^0 is a baryon with a strangeness of -1 One possible decay for a Λ^0 is**0 1 . 1**Deduce the quark structure of a Λ^0 .**[1 mark]**

0 1 . 2

State and explain which interaction is involved in this decay.

[2 marks]

0 1 . 3An antiparticle of the neutral lambda particle decays into a neutral pion and particle **X**.Identify **X**.**[1 mark]**



0 1 . 4 The rest energy of a Λ^0 is equal to the energy of a photon with a frequency of 2.69×10^{23} Hz.

Determine, in MeV, the rest energy of a Λ^0 .

[1 mark]

rest energy = _____ MeV

0 1 . 5 The discovery of particles such as the Λ^0 is made by large international research teams.

Suggest **one** reason for this.

[1 mark]

6

Turn over for the next question

Turn over ►



There are no questions printed on this page

*Do not write
outside the
box*

**DO NOT WRITE ON THIS PAGE
ANSWER IN THE SPACES PROVIDED**



0 2

In 2021 the world land speed record was 1230 km h^{-1} .

This was the average speed achieved by a jet-powered car in two runs. Each run was measured over a distance of 1.61 km.

0 2 . 1

The average speed for one of these runs was 343 m s^{-1} .

Calculate, in s, the time taken for the car to complete the other run.

[2 marks]

time = _____ s

Question 2 continues on the next page**Turn over ►**

0 2 . 2 Engineers are designing a new jet-powered car to break this record.

Figure 1 shows the variation of speed with distance for the car, as predicted by the engineers.

Figure 1

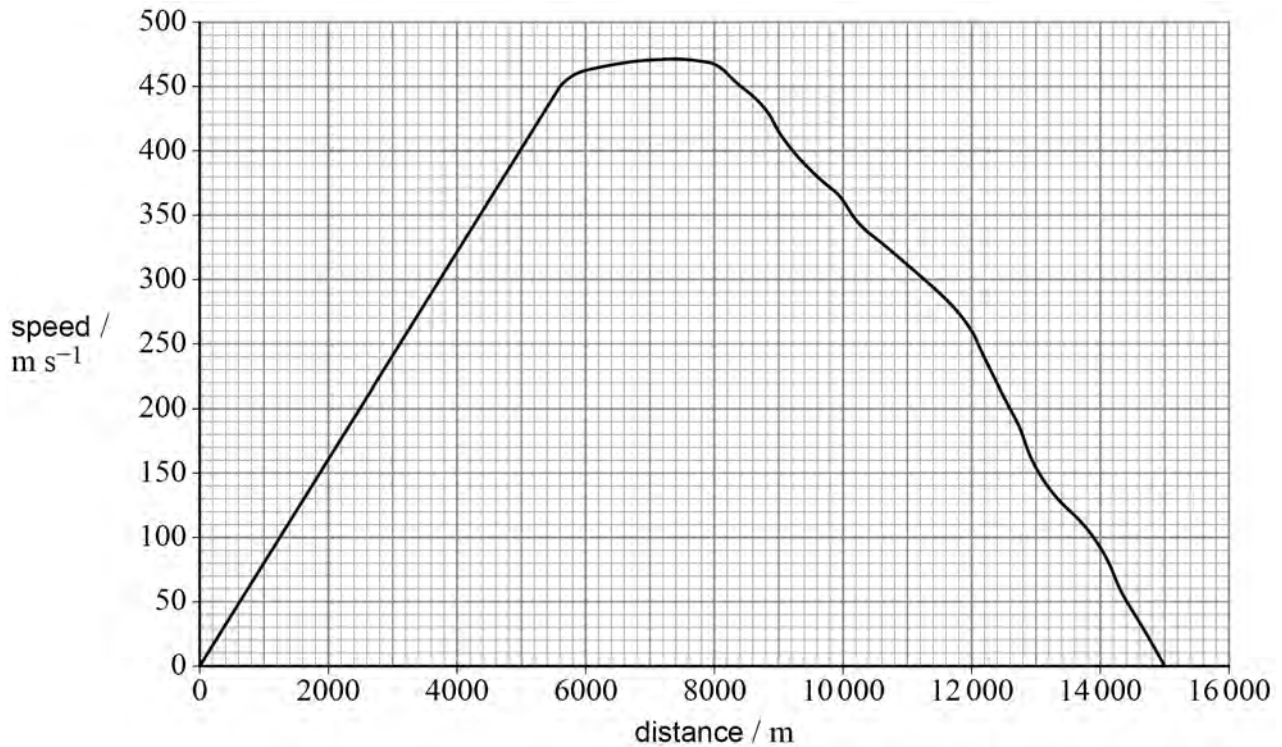

The car reaches its maximum acceleration when it is 5600 m from the start.
At this point the mass of the car is 6.50×10^3 kg.

Determine the kinetic energy of the car at its maximum acceleration.

[2 marks]

kinetic energy = _____ J



0 2 . 3 At any point on the graph in **Figure 1**, the acceleration is given by:

$$\text{acceleration} = \text{speed} \times \text{gradient of line}$$

When the car is at its maximum acceleration, the power input to the jet engines is 640 MW.

Calculate the percentage of the input power used to accelerate the car at its maximum acceleration.

[4 marks]

percentage of input power = _____ %

0 2 . 4 Scientists recommend that the average deceleration of the driver of the car should be less than $3g$.

Deduce whether the average deceleration is less than $3g$.

[2 marks]

10

Turn over ►



There are no questions printed on this page

*Do not write
outside the
box*

**DO NOT WRITE ON THIS PAGE
ANSWER IN THE SPACES PROVIDED**



0 3 . 1 In **Figure 2** the cell has emf ε and internal resistance r .

Figure 2

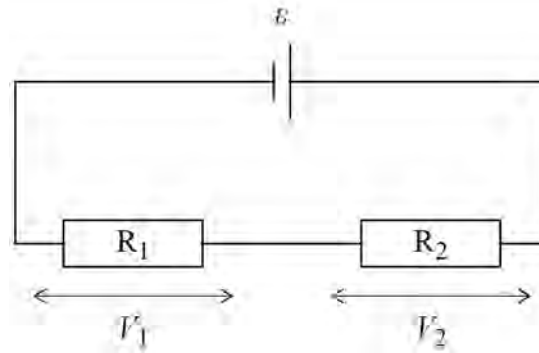

The current in the circuit is I .

The potential difference (pd) across R_1 is V_1 and the pd across R_2 is V_2 .

Explain how the law of conservation of energy applies in this circuit.

You should consider the movement of one coulomb of charge around the circuit.

[2 marks]

Question 3 continues on the next page

Turn over ►



Figure 3 shows a variable resistor made with a thin conducting layer on an insulating base.

Figure 3

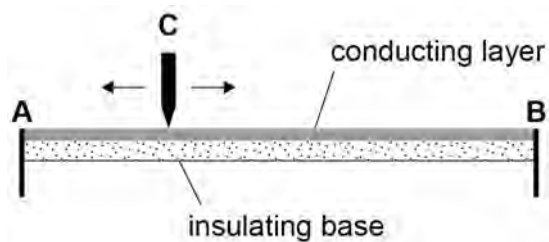

The conducting layer has constant width and thickness and has connections at the ends **A** and **B**.

C is a sliding contact that can move along the surface of the conducting layer between **A** and **B**.

Figure 4 shows a circuit that uses the variable resistor as a potential divider.

Figure 4

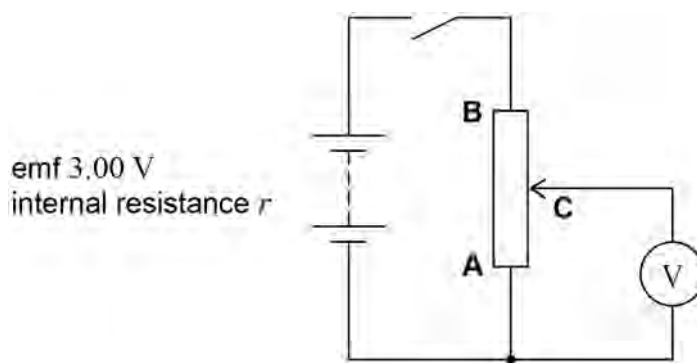

The variable resistor is connected to a battery of emf 3.00 V and internal resistance r . The resistance of the conducting layer between **A** and **B** is 125 Ω .



0 3 . 2

The sliding contact **C** is moved to end **B** of the variable resistor. The switch is closed. The digital voltmeter reads 2.89 V.

Show that r is approximately 4.8Ω .

[3 marks]**0 3 . 3**

C is set at $\frac{1}{5}$ of the distance between **A** and **B**. The thickness of the conducting layer is uniform so the resistance between **A** and **C** is 25.0Ω .

Determine the voltmeter reading at this setting.

[2 marks]

voltmeter reading = _____ V

Question 3 continues on the next page

Turn over ►

0 3 . 4

Figure 5 shows a variable resistor similar to the one shown in **Figure 3** but with the following three manufacturing faults:

- at **P** the conducting layer changes in thickness so that **AP** is thinner than **PB**
- at **Q** there is a scratch into the surface of the conducting layer and across its full width
- from **R** to **B** the conducting connector is laid over the conducting layer.

The width of the conducting layer is constant.

A pd of 3.0 V is applied across **A** and **B**.
C is moved from **A** to **B**.

Figure 5

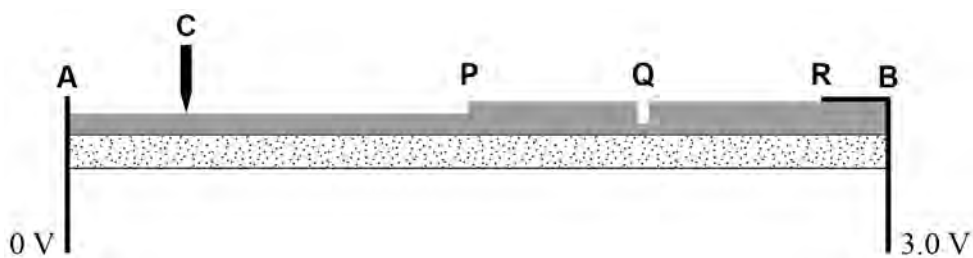

Sketch, on the axes in **Figure 6**, a graph to show how the pd between **A** and **C** varies as **C** is moved from **A** to **B**.

[4 marks]

Figure 6

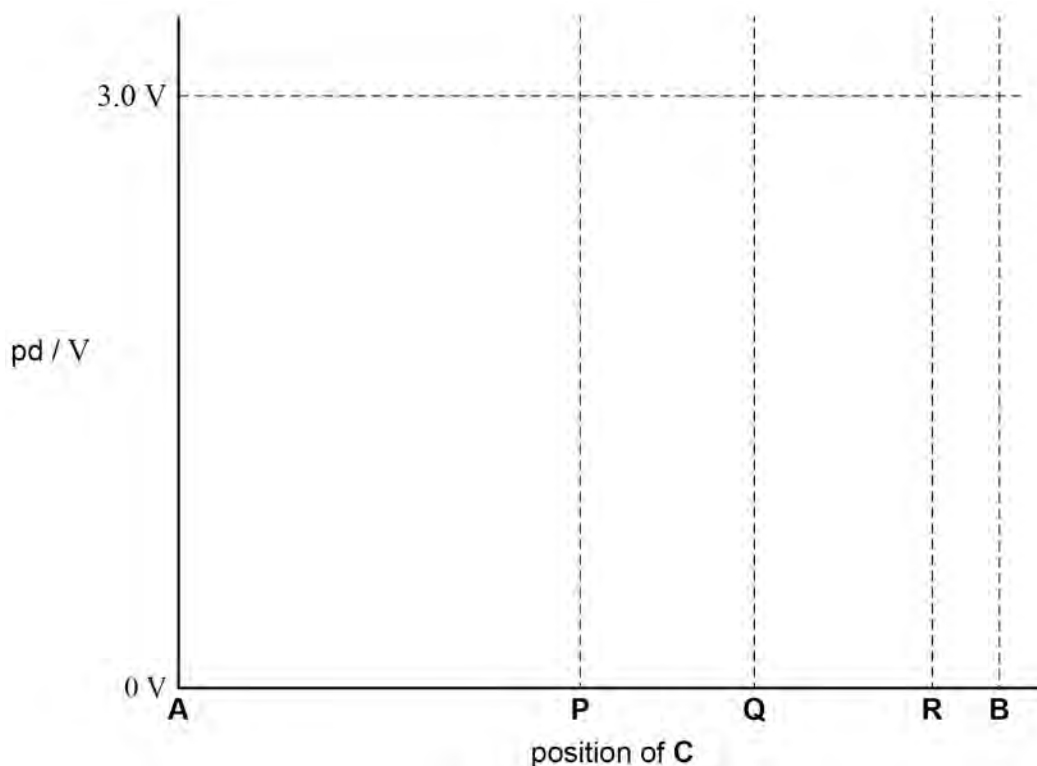

0 4

Porro prisms are used in binoculars to reverse the path of the light. The prism is in the shape of a right-angled isosceles triangle.

Figure 7 shows a ray of light, at normal incidence on the longest side, passing through a glass Porro prism.

Figure 7

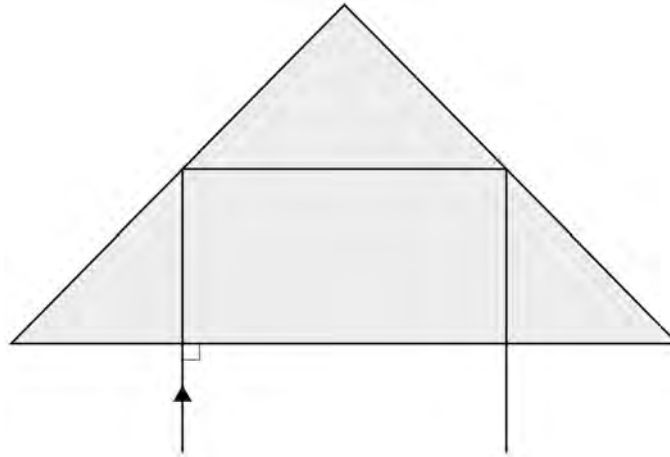

The critical angle for light in the prism is 41.5° .

0 4 . 1

Show that the glass used to make the prism has a refractive index of about 1.5

[1 mark]

0 4 . 2

Explain why the ray emerges parallel to the incident ray.

[2 marks]

Question 4 continues on the next page

Turn over ►



Figure 8 shows a ray of light entering the prism at an angle of incidence θ and reflecting off one of the shorter sides.

Figure 8

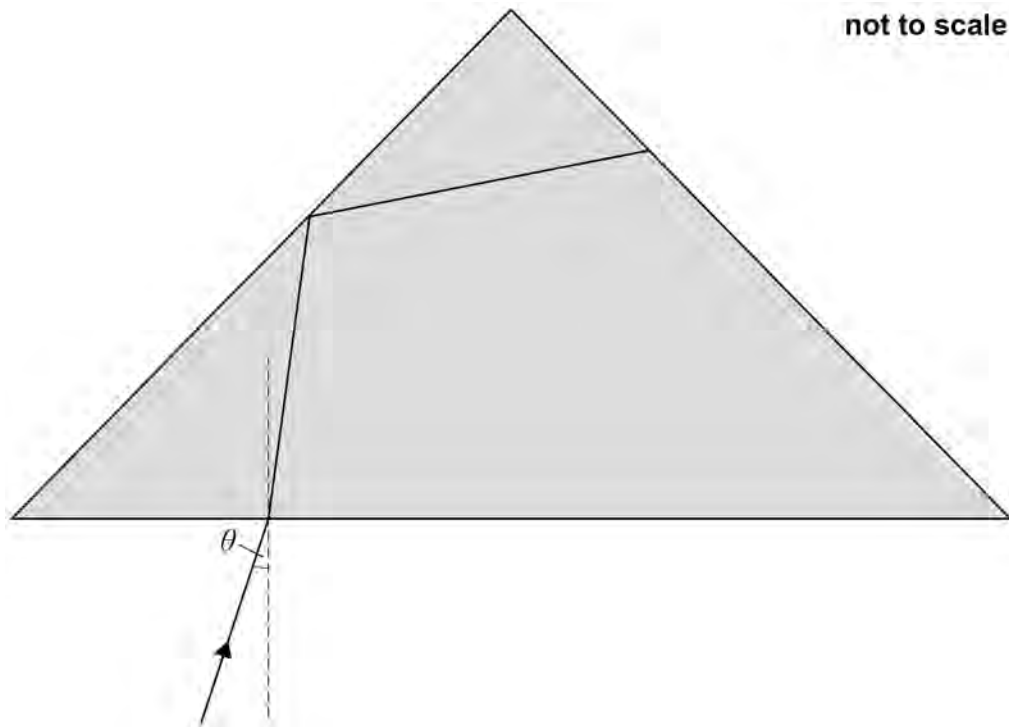

θ is the largest angle of incidence for which all of the light leaves through the longest side.

0 4 . 3

Draw on **Figure 8** the path of the ray of light as it continues inside the prism and emerges from the longest side.

[3 marks]



0 4 . 4

When the angle of incidence is greater than θ , some of the light escapes the prism through one of the shorter sides.

Assume that the refractive index is 1.5 and the critical angle is 41.5° .

Show that θ is about 5° .

You can use **Figure 8** in your answer.

[4 marks]

Question 4 continues on the next page

Turn over ►



0 4 . 5

A manufacturer wants to make a prism with a larger value of θ .

Two alternative changes to the original design of the prism are suggested:

1. use a prism of the original glass in the shape of an equilateral triangle, as shown in **Figure 9**
2. use a prism of the original shape made from glass with a smaller refractive index, as shown in **Figure 10**.

Figure 9

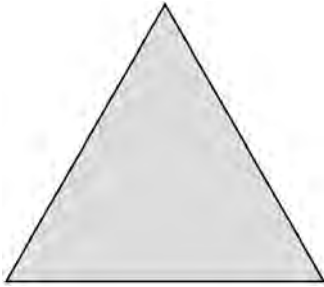
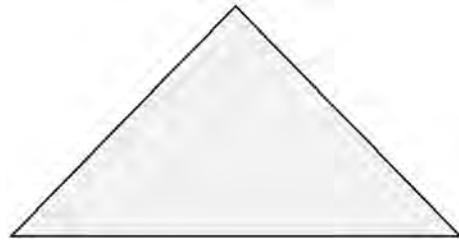

Figure 10



Discuss whether either of the two suggestions would work.

[4 marks]

1 _____

2 _____

14



0 5

Figure 11 shows the stress–strain graph for a metal in tension up to the point at which it fractures.

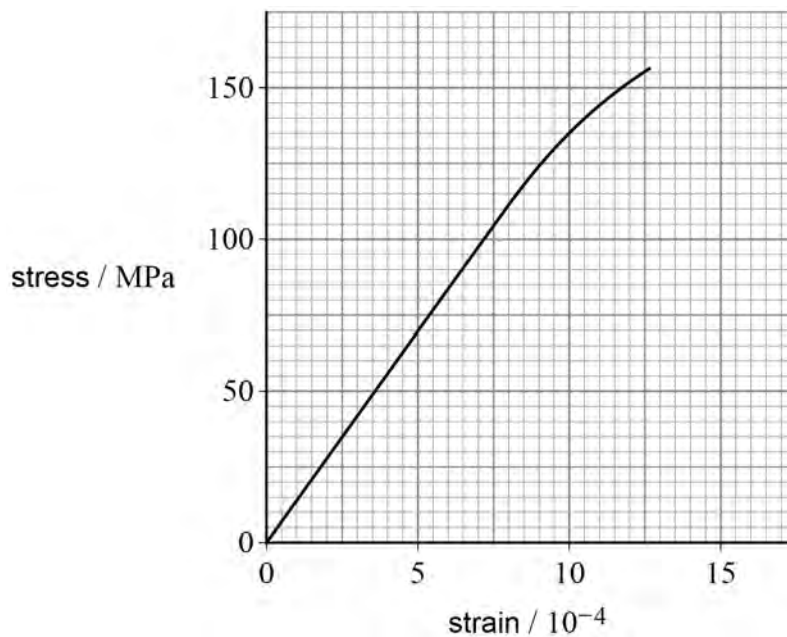
Figure 11

0 5 . 1

Determine, using **Figure 11**, the Young modulus of the metal.

[1 mark]

Young modulus = _____ Pa

0 5 . 2

Explain how the graph shows that this metal is brittle.

[1 mark]

Question 5 continues on the next page

Turn over ►



Figure 12 shows a uniform rigid lighting beam **AB** suspended from a fixed horizontal support by two identical vertical steel wires. A lamp is attached to the midpoint of **AB**.

Figure 12

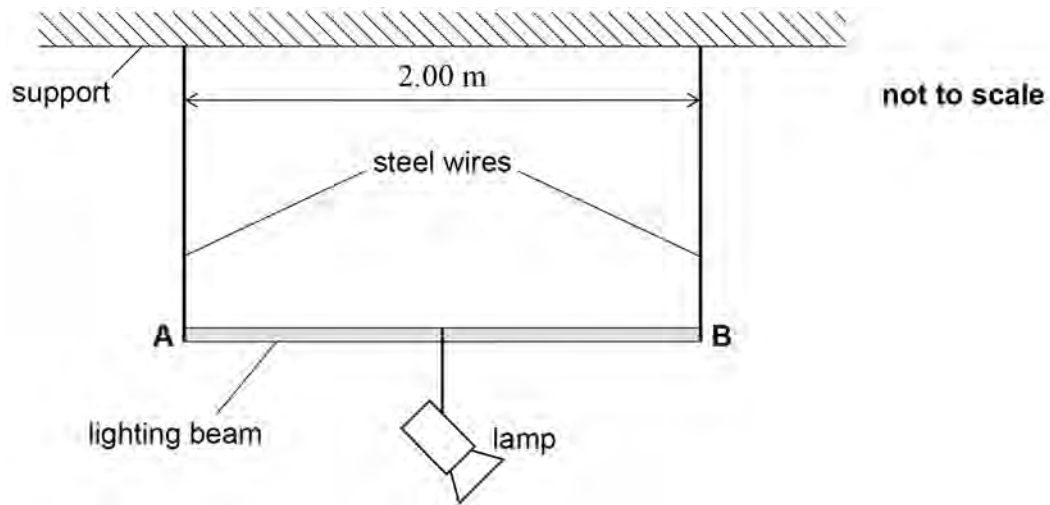

The unloaded length of each steel wire was 1.20 m before it was attached to **AB**. **AB** is horizontal.

- mass of **AB** = 4.4 kg
- mass of lamp = 16.0 kg
- distance between wires = 2.00 m
- diameter of each wire = 0.800 mm
- Young modulus of steel = 2.10×10^{11} Pa

0 5 . 3 Calculate the extension of each wire.

[3 marks]

extension = _____ m



0 5 . 4

The right-hand steel wire is removed and replaced with an aluminium wire of diameter 1.60 mm. The unloaded length of the aluminium wire is the same as that of the original steel wire.

When the lamp is at the midpoint of **AB**, one of the wires extends more than the other so that **AB** is not horizontal. To make **AB** horizontal the lamp has to be moved to a distance x from **A**. **Figure 13** shows the new arrangement.

Figure 13

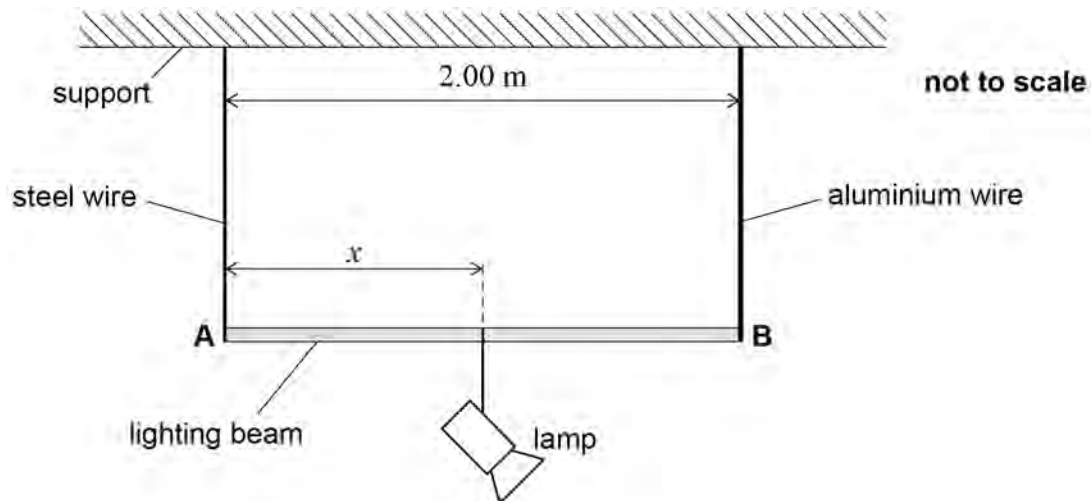

The Young modulus of aluminium is 7.00×10^{10} Pa.

Deduce distance x .

[5 marks]

$x =$ _____ m

10

Turn over ►



0 6

A pencil is weighted with a thin coil of wire. The volume of the wire is negligible. **Figure 14** shows the pencil and wire floating in equilibrium in water.

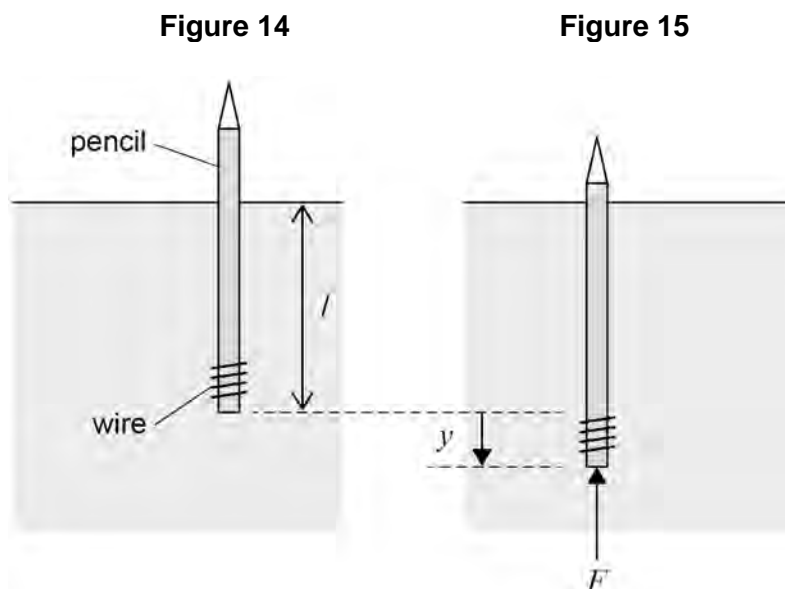

In **Figure 14** the combined weight of the pencil and wire is equal to an upwards force called the buoyancy force. The length of the pencil that is submerged is l . A student pushes the pencil down through a displacement y as shown in **Figure 15**. The buoyancy force is now greater than the weight. There is a resultant upward force F acting on the pencil when the student releases it. The magnitude of F for any value of y is given by

$$F = A\rho gy$$

where A is the cross-sectional area of the pencil

ρ is the density of water

g is the acceleration due to gravity.

The pencil is pushed down and released. The pencil then oscillates vertically about the equilibrium position.



0 6 . 1 Show that the pencil moves with simple harmonic motion.

[2 marks]

0 6 . 2 The time period T of the vertical oscillations is given by

$$T = 2\pi \sqrt{\frac{l}{g}}$$

The measured value of l in **Figure 15** is 85 mm.
The pencil is pushed down 5.0 mm and released.

Calculate the maximum acceleration of the pencil.

[2 marks]

maximum acceleration = _____ m s^{-2}

Question 6 continues on the next page

Turn over ►



A ship floating in the sea can be modelled by the pencil floating in water. The ship can oscillate vertically. These oscillations are called heave oscillations.

Wave motion causes forced oscillations of the ship. Under certain conditions, heave resonance may then occur.

0 6 . 3 Explain what is meant by resonance.

[2 marks]

0 6 . 4 **Figure 16** shows a ship moving through continuous waves of wavelength 118 m and velocity 14.2 m s^{-1} .

The ship is moving steadily at 8.0 m s^{-1} relative to the seabed in the same direction as the waves.

Figure 16

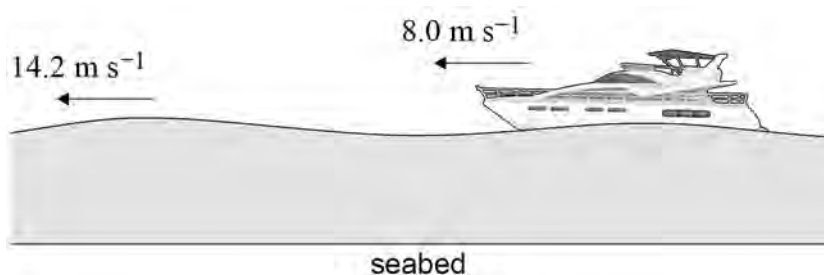

The natural frequency of heave oscillations of the ship is 0.13 Hz.

A crew member needs an emergency operation. The ship's doctor is confident that she can do the operation if the ship remains fairly steady.

There are two options:

- stop the ship's motors and loosely anchor the ship to the seabed
- continue to sail the ship at 8.0 m s^{-1} in the same direction.

Deduce which is the better option.
Support your answer with a calculation.

[3 marks]

9

END OF SECTION A

Turn over ►



Section B

Each of Questions **07** to **31** is followed by four responses, **A**, **B**, **C** and **D**.

For each question select the best response.

Only **one** answer per question is allowed.

For each question, completely fill in the circle alongside the appropriate answer.

CORRECT METHOD

WRONG METHODS

If you want to change your answer you must cross out your original answer as shown. 

If you wish to return to an answer previously crossed out, ring the answer you now wish to select as shown. 

You may do your working in the blank space around each question but this will not be marked.
Do **not** use additional sheets for this working.

07

Which combination of an object's speed and journey time gives a distance travelled of 1 mm?

[1 mark]

	Speed	Journey time	
A	$10 \mu\text{m s}^{-1}$	100 s	<input type="radio"/>
B	10 km s^{-1}	$0.01 \mu\text{s}$	<input type="radio"/>
C	1 nm s^{-1}	1 Gs	<input type="radio"/>
D	0.1 Mm s^{-1}	100 ns	<input type="radio"/>



0 8 A person jumps as high as she can from a standing position.

What is a reasonable estimate of her speed just after she leaves the ground?

[1 mark]

A 2 m s^{-1}

B 4 m s^{-1}

C 8 m s^{-1}

D 10 m s^{-1}

0 9 A nucleus contains N neutrons and Z protons.

Which combination of N and Z gives a nucleus with the greatest specific charge?

[1 mark]

	N	Z	
A	6	5	<input type="checkbox"/>
B	8	7	<input type="checkbox"/>
C	16	13	<input type="checkbox"/>
D	20	17	<input type="checkbox"/>

1 0 Which statement about muons is correct?

[1 mark]

A They consist of a quark and an antiquark.

B They include pions and kaons.

C They are subject to the strong interaction.

D They decay into electrons.

Turn over ►



1 1

The diagram represents a quark change in which an electron antineutrino is produced.

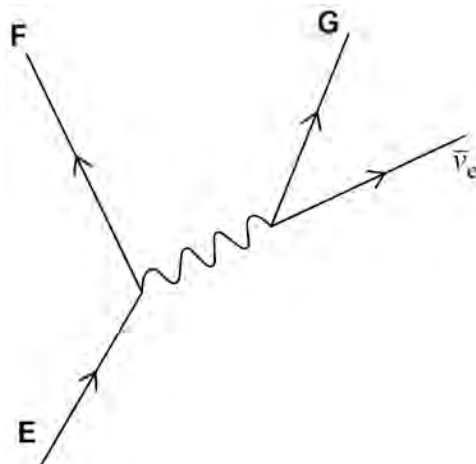

What are **E**, **F** and **G**?

[1 mark]

	E	F	G	
A	up quark	down quark	β^-	<input type="checkbox"/>
B	down quark	up quark	β^-	<input type="checkbox"/>
C	up quark	down quark	β^+	<input type="checkbox"/>
D	down quark	up quark	β^+	<input type="checkbox"/>

1 2

Photoelectrons are released when monochromatic light with a photon energy of 4.2×10^{-19} J is incident on a metal surface. The work function of the surface is 2.4 eV.

What is the maximum speed of the photoelectrons as they leave the surface?

[1 mark]

- A** 1.3×10^6 m s⁻¹
- B** 6.3×10^5 m s⁻¹
- C** 2.8×10^5 m s⁻¹
- D** 2.0×10^5 m s⁻¹



1 3

Electrons with a certain kinetic energy pass through a powdered crystalline sample and are incident on a fluorescent screen.

The diagram shows a sketch of the diffraction pattern produced.



A change is made and this second pattern is produced.



Which change could produce the second pattern?

[1 mark]

- A** decreasing the kinetic energy of the electrons
- B** replacing the electrons with protons with the same kinetic energy
- C** using a crystalline sample with a wider spacing between its atoms
- D** moving the screen closer to the crystalline sample

Turn over ►



1 4

A string with a length of 1.2 m vibrates at its second harmonic.
The diagram shows the displacement–time graph for a point on the string.

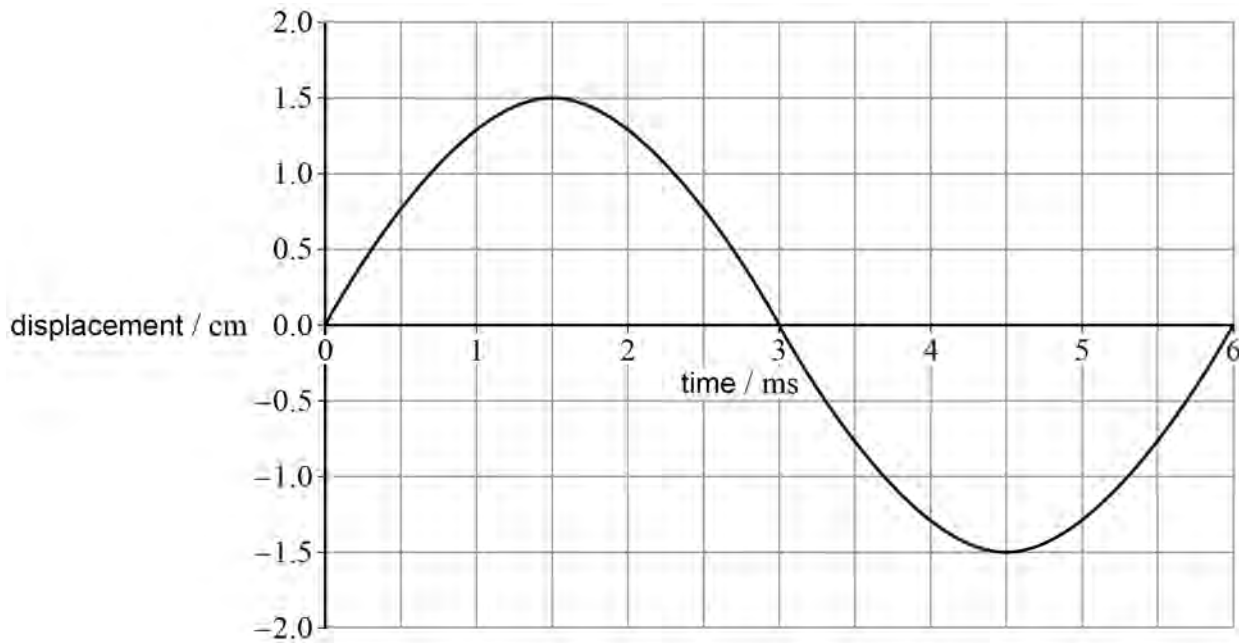

What are the wavelength and frequency of the wave on the string?

[1 mark]

	Wavelength / m	Frequency / kHz	
A	0.6	0.17	<input type="radio"/>
B	0.6	0.34	<input type="radio"/>
C	1.2	0.17	<input type="radio"/>
D	1.2	0.34	<input type="radio"/>



1 5

A standing wave is created on a string.

Which statement about the two waves that create the standing wave is **not** correct?

[1 mark]

- A** They have the same frequency.
- B** They have a constant phase relationship.
- C** They travel in opposite directions.
- D** They have the same speed.

1 6

A double slit with a separation s is illuminated by light of wavelength λ .

Fringes with spacing w are produced on a screen placed a distance D from the slits.

The distance from the slits to the screen is changed to $\frac{D}{2}$.

Which combination of slit separation and wavelength produces a fringe spacing of $1.5w$ on the screen?

[1 mark]

	Slit separation	Wavelength	
A	$0.22s$	0.66λ	<input type="radio"/>
B	$0.50s$	0.75λ	<input type="radio"/>
C	$0.60s$	1.20λ	<input type="radio"/>
D	$1.20s$	0.40λ	<input type="radio"/>

Turn over for the next question

Turn over ►



1 7

A single narrow slit is illuminated with monochromatic light and a diffraction pattern is produced.

The slit width is increased.

What happens to the width and brightness of the central maximum of the diffraction pattern?

[1 mark]

	Width of central maximum	Brightness of central maximum	
A	increases	increases	<input type="radio"/>
B	increases	decreases	<input type="radio"/>
C	decreases	increases	<input type="radio"/>
D	decreases	decreases	<input type="radio"/>

1 8

A ball is kicked from point **P** on level ground. The ball initially travels at 45° to the horizontal.

The ball reaches its maximum height after a time of 2.0 s.

Air resistance can be ignored.

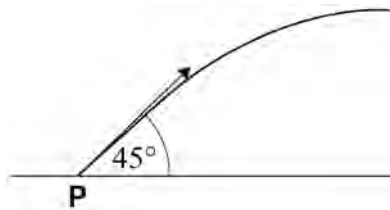

What is the displacement of the ball from **P** when at its maximum height?

[1 mark]

- A** 20 m
- B** 40 m
- C** 45 m
- D** 60 m



1 9

An object is moving in a straight line. A graph is plotted to show the variation of the momentum of the object with time.

Which quantities can be calculated from the gradient of the graph and the area under the graph?

[1 mark]

	Gradient of graph	Area under graph	
A	power	mass \times displacement	<input type="checkbox"/>
B	force	work done \times time	<input type="checkbox"/>
C	power	work done \times time	<input type="checkbox"/>
D	force	mass \times displacement	<input type="checkbox"/>

2 0

Which is a pair of vectors?

[1 mark]

- A** weight and work
- B** force and energy
- C** displacement and momentum
- D** acceleration and power

2 1

Which statement about a superconducting metal is correct?

[1 mark]

- A** Its resistivity is small but not zero.
- B** A current in it causes no heating effect.
- C** Its critical temperature is independent of the metal it is made from.
- D** Keeping it cold makes it too expensive to use.

Turn over ►

- 2 2** A heavy uniform trapdoor is hinged to the floor. It is held open by a rope as shown.

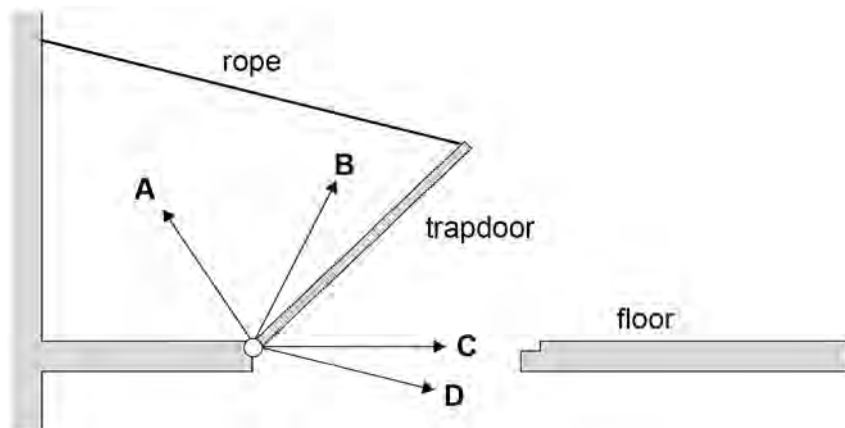

Which arrow shows the direction of the reaction force of the hinge on the trapdoor?

[1 mark]

- A
- B
- C
- D

- 2 3** A sphere of mass m falls with speed v .
The resistive force on the sphere is kv , where k is a constant.

What is the terminal speed of the sphere?

[1 mark]

- A $\frac{mg}{k}$
- B $\frac{km}{g}$
- C kmg
- D $\frac{k}{mg}$



2 4

A trolley moves down a slope with constant acceleration. The mass of the trolley is doubled and the trolley moves down the same slope again. Air resistance and friction are negligible.

Which is correct?

[1 mark]

- A** The accelerating force is unchanged.
- B** The accelerating force is halved.
- C** The acceleration is unchanged.
- D** The acceleration is halved.

2 5

A variable force F acts on an object of mass 2.0 kg. The object is at rest at time $t = 0$

The graph shows the variation of F with t .

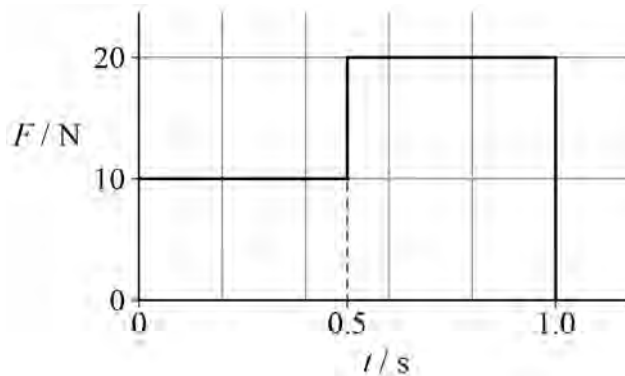

What is the speed of the object when $t = 1.0$ s?

[1 mark]

- A** 3.75 m s^{-1}
- B** 5.00 m s^{-1}
- C** 7.50 m s^{-1}
- D** 15.0 m s^{-1}

Turn over ►



2 6

A heavy cable is attached to a fixed support and carries a load at its lower end.

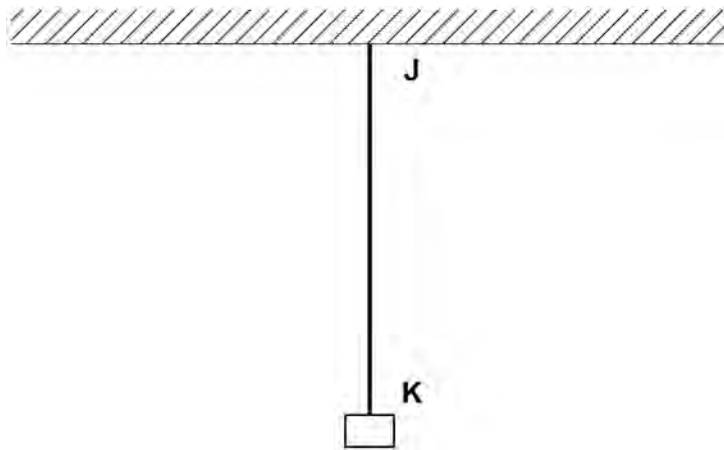

The weight of the cable is **not** negligible.
The cable has constant cross-sectional area and density.

Which graph shows the variation of tensile stress σ in the cable with distance d from J to K?

[1 mark]

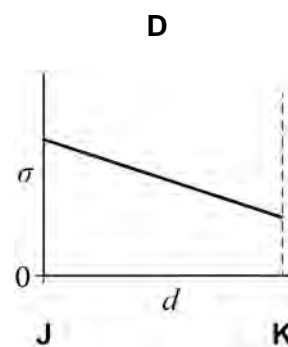
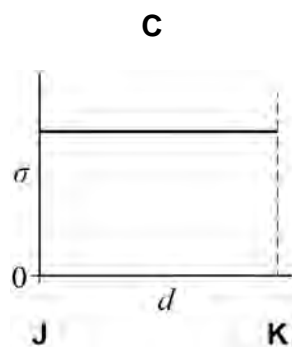
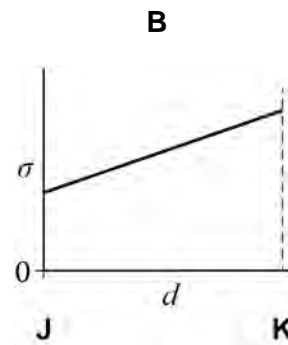
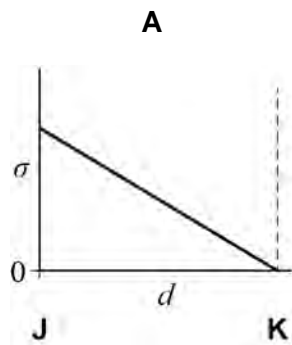
A B C D 

2 7

A box with four terminals is connected to a cell and two ammeters. The top left terminal is **X**.

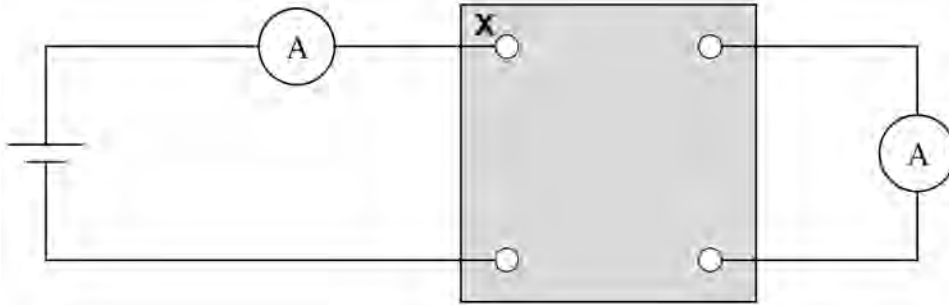

Each of the boxes **A** to **D** is connected into the circuit in turn. All the resistors have equal resistance.

Which box gives the same reading on both ammeters?

[1 mark]

A

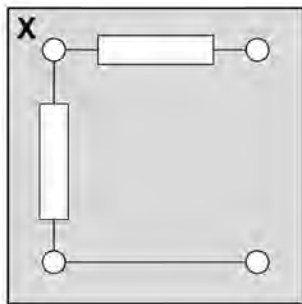

B

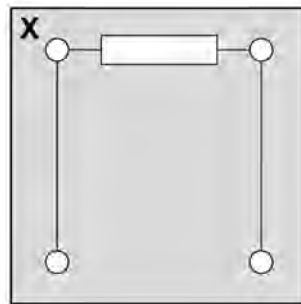

C

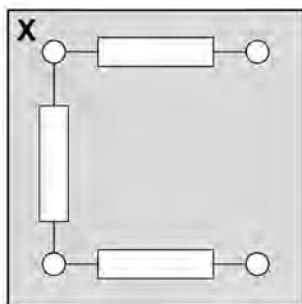

D

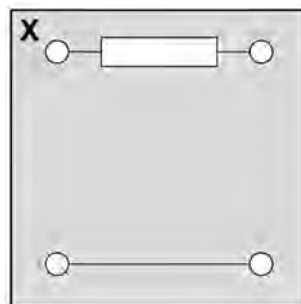

A

B

C

D

Turn over ►



2 8

Two circular discs made of card rotate at constant speed on a common axle.

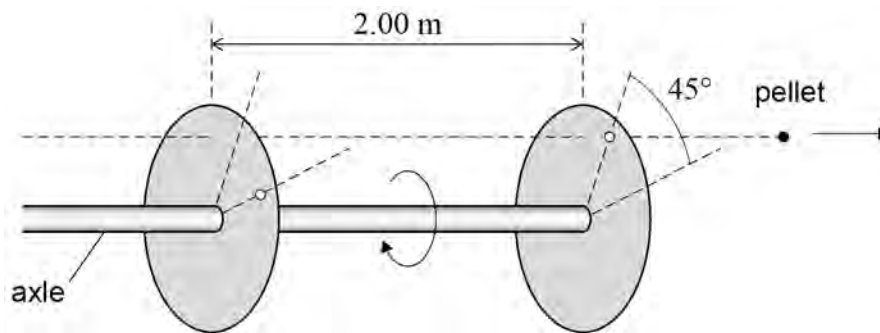

The discs are 2.00 m apart.

An air-gun pellet is fired parallel to the axle. The pellet makes holes in the discs.

The holes are separated by an angle of 45° .

The speed of the pellet between the discs is 300 m s^{-1} .

How many revolutions does each disc complete in one second?

[1 mark]

- A 19
- B 118
- C 740
- D 1074

2 9

A resistor dissipates 100 W when connected across a 25 V supply with negligible internal resistance.

The supply output is reduced to 20 V and the resistor is replaced so that the power dissipated is still 100 W.

What is the percentage decrease in resistance?

[1 mark]

- A 20
- B 36
- C 64
- D 80



3 0

When an aircraft turns in a horizontal circular path, it banks at an angle θ .

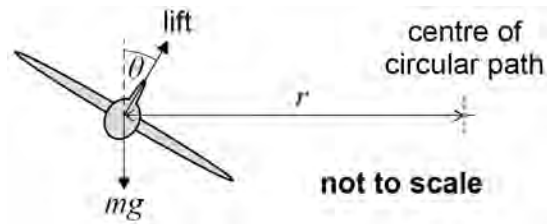

The aircraft has mass m and travels at constant speed v in a horizontal circular path of radius r . The lift force acts at the angle θ .

What is $\tan \theta$?

[1 mark]

A $\frac{gv^2}{r}$

B $\frac{rv^2}{g}$

C $\frac{rg}{v^2}$

D $\frac{v^2}{rg}$

3 1

A mass, attached to two springs, oscillates horizontally between **P** and **Q**. The motion of the system is simple harmonic.

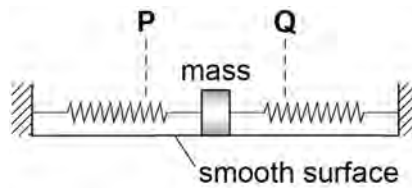

Which quantity has its magnitude at a minimum value when the mass is at **Q**?

[1 mark]

A the acceleration of the mass

B the kinetic energy of the mass

C the potential energy of the mass–spring system

D the resultant force of the springs on the mass

25

END OF QUESTIONS

There are no questions printed on this page

*Do not write
outside the
box*

**DO NOT WRITE ON THIS PAGE
ANSWER IN THE SPACES PROVIDED**



